

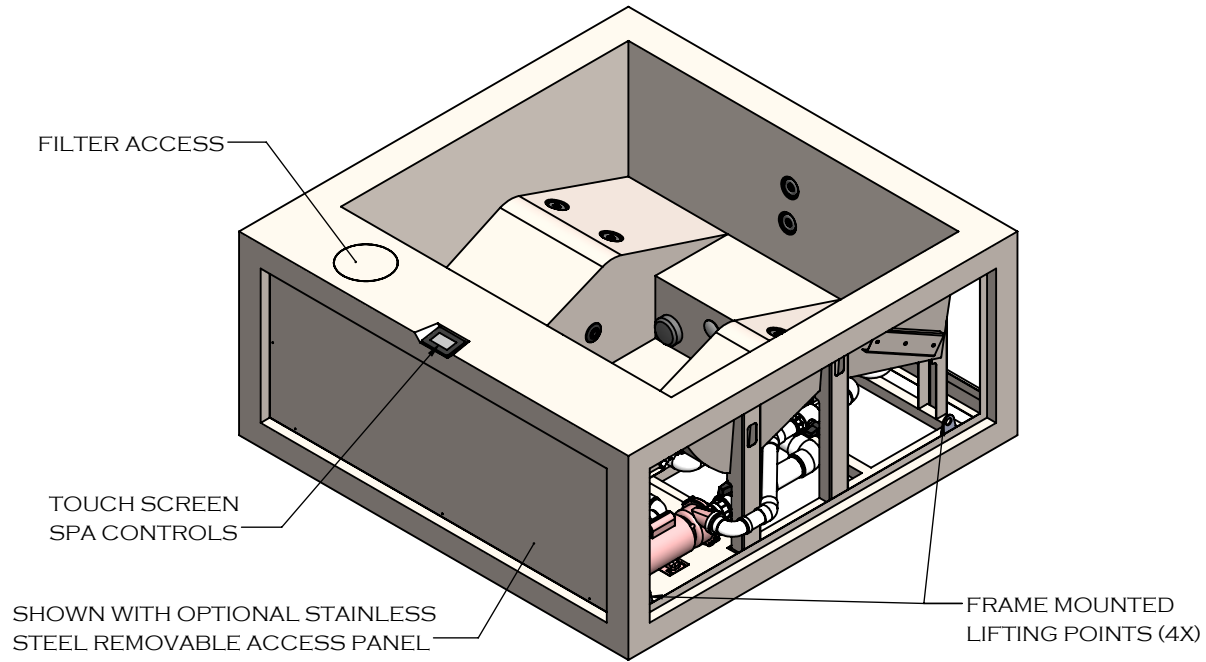

# WINDOM PORTABLE SPA

## STAINLESS STEEL ABOVE GROUND

### SPECIFICATIONS



#### FEATURES:

- 316L STAINLESS STEEL SPA SHELL WITH 304L STAINLESS STEEL FRAME
- REMOVABLE ACCESS PANELS ARE AVAILABLE IN STAINLESS STEEL OR COPPER
- 4 BATHER CAPACITY DUAL LOUNGER LAYOUT
- LED LIGHTING
- 14 HYDROTHERAPY JETS
- FULLY INSULATED WITH 2-PART POLYURETHANE FOAM (NOT SHOWN)
- RIGID FOAM COVER WITH R-15 INSULATION AND ASTM CERTIFICATION
- UV LIGHT & HYDROGEN PEROXIDE SANITIZATION
- OVERALL DIMENSIONS: 86" X 86" X 39"
- WATER CAPACITY: 312 GALLONS
- EMPTY WEIGHT: 1,562 LBS
- FULL WEIGHT: 4,168 LBS

#### CERTIFICATIONS:

STAINLESS STEEL & COPPER SHELLS:

- IAPMOEGS LISTING FOR UL 1795 AND CSA C22.2 STANDARDS

#### POWER REQUIREMENTS:

- (1X) 230V 50A GFCI SERVICE AT EQUIPMENT FOR SPA CONTROL AND 5.5KW ELECTRIC HEATER
- SPA SHELL AND ALL EQUIPMENT TO BE BONDED W/ MIN. #6AWG BARE COPPER CONDUCTOR

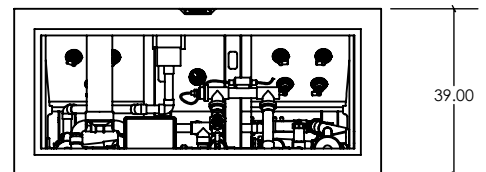
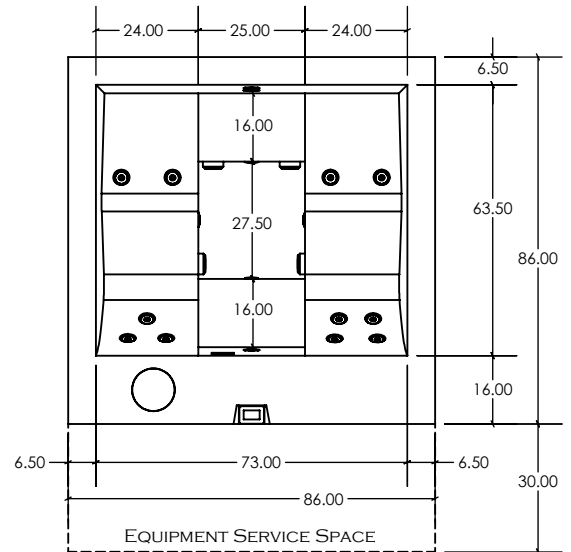



# WINDOM PORTABLE SPA

## COPPER ABOVE GROUND

### SPECIFICATIONS

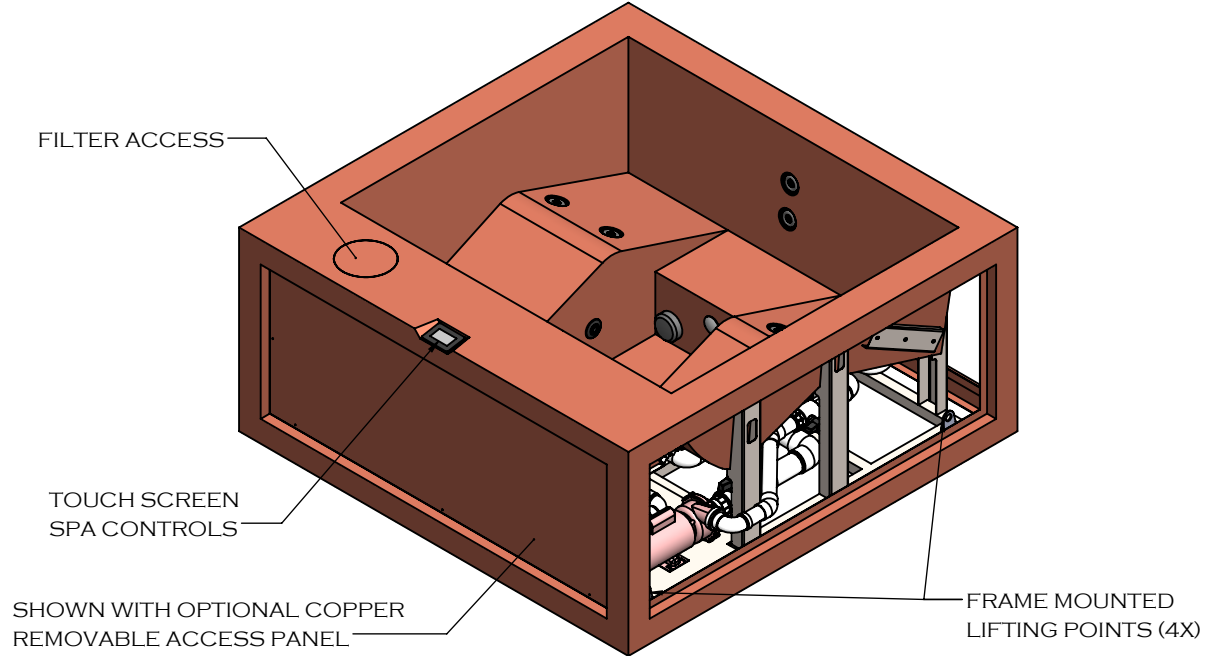

#### FEATURES:

- COPPER SPA SHELL WITH 304L STAINLESS STEEL SUPPORT FRAME
- REMOVABLE ACCESS PANELS ARE AVAILABLE IN STAINLESS STEEL OR COPPER
- 4 BATHER CAPACITY DUAL LOUNGER LAYOUT
- LED LIGHTING
- 14 HYDROTHERAPY JETS
- FULLY INSULATED WITH 2-PART POLYURETHANE FOAM (NOT SHOWN)
- RIGID FOAM COVER WITH R-15 INSULATION AND ASTM CERTIFICATION
- UV LIGHT & HYDROGEN PEROXIDE SANITIZATION
- OVERALL DIMENSIONS: 86" X 86" X 39"
- WATER CAPACITY: 312 GALLONS
- EMPTY WEIGHT: 1,660 LBS
- FULL WEIGHT: 4,266 LBS

#### CERTIFICATIONS:

- STAINLESS STEEL & COPPER SHELLS:
- IAPMOEGS LISTING FOR UL 1795 AND CSA C22.2 STANDARDS

#### POWER REQUIREMENTS:

- (1X) 230V 50A GFCI SERVICE AT EQUIPMENT FOR SPA CONTROL AND 5.5KW ELECTRIC HEATER
- SPA SHELL AND ALL EQUIPMENT TO BE BONDED W/ MIN. #6AWG BARE COPPER CONDUCTOR

