



# FRASER COLD PLUNGE

## STAINLESS STEEL ABOVE GROUND

### SPECIFICATIONS

SPEC SHEET FOR PRE-PLANNING  
& ESTIMATING ONLY

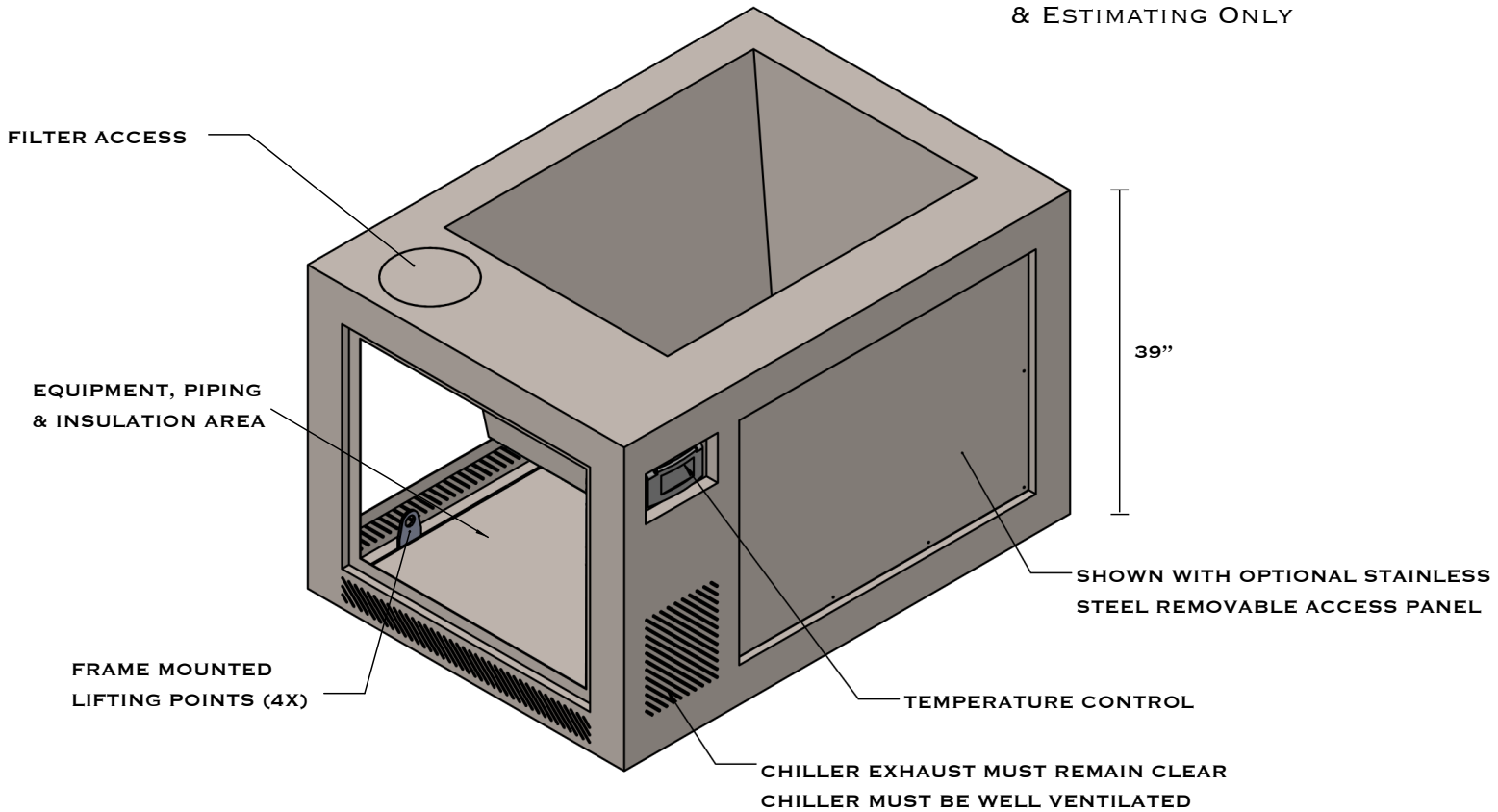

#### FEATURES:

- + 316L STAINLESS STEEL SHELL WITH 304L STAINLESS STEEL FRAME
- + REMOVABLE ACCESS PANELS ARE AVAILABLE IN STAINLESS STEEL OR COPPER
- + 1 BATHER CAPACITY
- + FULLY INSULATED WITH 2-PART POLYURETHANE FOAM (NOT SHOWN)
- + RIGID FOAM COVER WITH R-15 INSULATION AND ASTM CERTIFICATION
- + UV LIGHT & HYDROGEN PEROXIDE SANITIZATION
- + OVERALL DIMENSIONS: 62" x 44" x 39"
- + WATER CAPACITY: 124 GALLONS
- + EMPTY WEIGHT: 882 LBS
- + FULL WEIGHT: 1,915 LBS
- + 1/4 HP WATER CHILLER

#### CERTIFICATIONS:

- STAINLESS STEEL & COPPER SHELLS:
- + IAPMOEGS LISTING FOR UL 1795 AND CSA C22.2 STANDARDS

#### POWER REQUIREMENTS:

- + (1X) 120V 20A GFCI SERVICE AT COLD PLUNGE

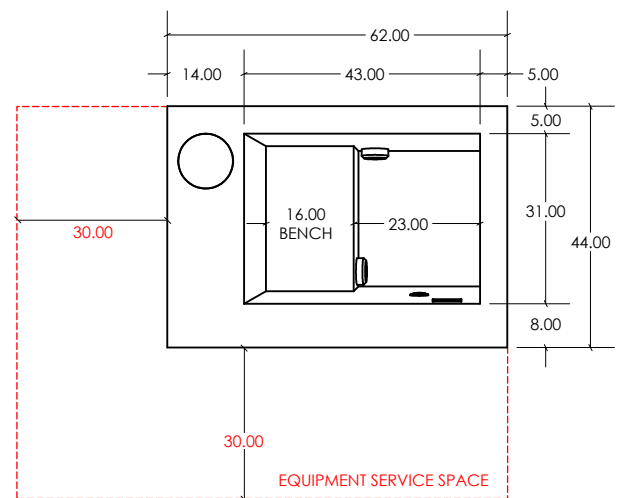

1.800.951.SPAS (7727) 720.864.9115 FAX 866.605.2358

DIAMONDSPAS.COM INFO@DIAMONDSPAS.COM